

Front view and mounting

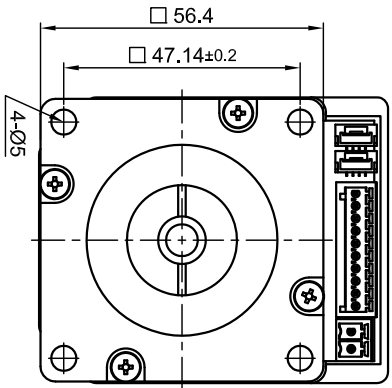

Side view

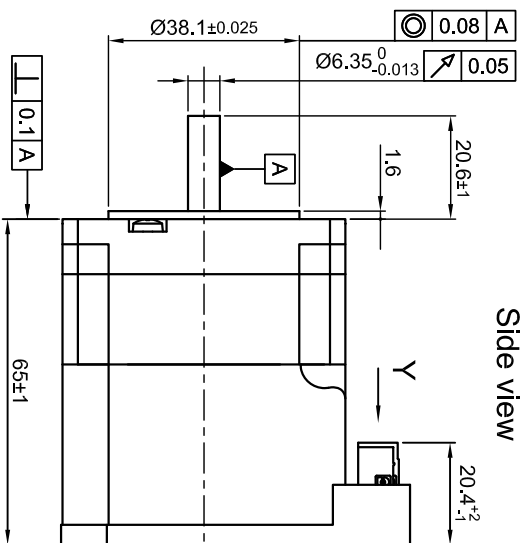

Rear view

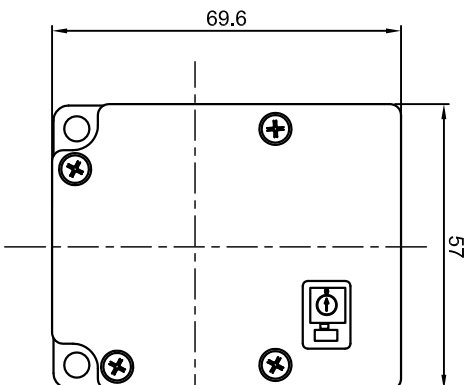

Y view

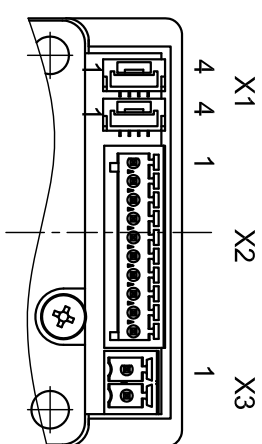

SPECIFICATION	CONNECTION
VOLTAGE (VDC)	BIPOLAR
AMPS/PHASE(A)	12 TO 48
HOLDING TORQUE (Nm) [lb-in]	4.2
DEIFTENT TORQUE (Nm) [lb-in]	0.537 [4.752]
STEP ANGLE (°)±ACCURACY	0.0147 [0.13]
WEIGHT (Kg) [lb]	1.8±5% TO MICROSTEP
	0.6 [1.32]

PERMISSIBLE RADIAL+AXIAL FORCE

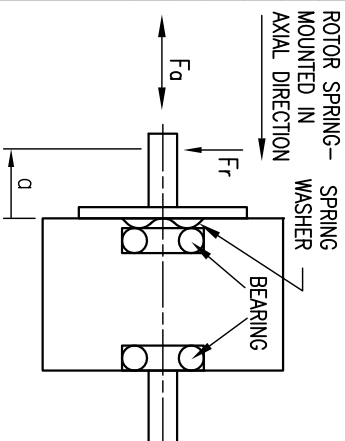

OVERTEMPERATURE PROTECTION (ELECTRONICS): 75°C	AXIAL-FORCE F <sub>a</sub> (N)	F <sub>a</sub> =10
AMBIENT TEMPERATURE -10°~ 50°C [14°F ~ 122°F] (HIGHER TEMPERATURE REDUCES DUTY CYCLE)	DISTANCE a (mm)	20
INSULATION RESISTANCE 100 Mohm (UNDER NORMAL TEMPERATURE AND HUMIDITY)	RADIAL-FORCE F <sub>r</sub> (N)	52
INSULATION CLASS B 130° [266°F]	AXIAL	RADIAL
DIELECTRIC STRENGTH 500VAC FOR 1 MIN. (BETWEEN THE MOTOR COILS AND THE MOTOR CASE)	SHAFT PLAY (mm)	0.2Mmax
AMBIENT HUMIDITY MAX. 85% (NO CONDENSATION)	AT LOAD MAX: (N)	200
		4.5

AXIAL-FORCE F <sub>a</sub> (N)	RADIAL-FORCE F <sub>r</sub> (N)
10	52
20	52
52	52
200	52

X1, JST GH-4	
PIN No.	Function
1	+UB_L06G(24V)
2	CAN+
3	CAN-
4	GND

X2, Phoenix MCV-10	
PIN No.	Function
1	GND
2	Analog input (0-10V)
3	+12V (Voltage Output, max.100mA)
4	Output1 (open drain)
5	Output2 (open drain)
6	Input1 (+5/+24V)
7	Input2 (+5/+24V)
8	Input3 (+5/+24V)
9	Input4 (+5/+24V)
10	GND

X3, Phoenix FMC-02	
PIN No.	Function
1	+VCC(12-48V)
2	GND

REV	DESCRIPTION	DATE	APVD

APVD	CHKD	DRN	SIGNATURE	DATE
G.M.	L.B	CYQ		01.07.16

Surface specification	General tolerances	Work piece edge
DIN ISO 1302	DIN ISO 2768-cH	DIN ISO 13715



PLUG&DRIVE MOTOR

DWG.NO PD4-C5918X4204-E-08